

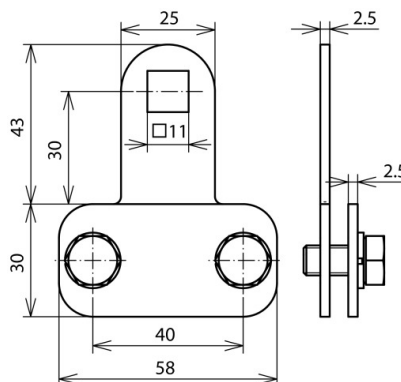

KS 200 B11.11 FL30X4 V2A (380 209)



Figure without obligation



Clamping piece with spring washer for connecting flat material to construction components. Lightning current carrying capability 200 kA (10/350 μ s)

Type	KS 200 B11.11 FL30X4 V2A
Part No.	380 209
Material	StSt
Clamping range FI	30 x 4 mm
Fixing	square hole 11 x 11 mm
Screw	M8 x 16 mm
Material of screw	StSt
Distance of screws	40 mm
Material thickness	2.5 mm
Lightning current carrying capability (10/350 μ s)	200 kA
Standard	based on EN 62561-1
Weight	102 g
Customs tariff number (Comb. Nomenclature EU)	85389099
GTIN	4013364158269
PU	1 pc(s)

We reserve the right to introduce changes in performance, configuration and technology, dimensions, weights and materials in the course of technical progress. The figures are shown without obligation.