

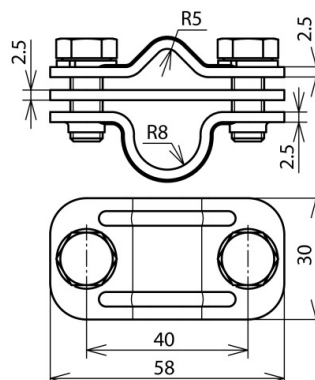

## UTK 200 8.10 16 ZP V2A (459 219)



Figure without obligation



Disconnecting clamp with spring washer for connecting air-termination rod and conductor or down conductor and earth entry rod. Tested for lightning current carrying capability up to 200 kA (10/350  $\mu$ s).

Type	UTK 200 8.10 16 ZP V2A
Part No.	459 219
Material	StSt
Clamping range Rd / Rd	8-10 / 16 mm
Screw	M8 x 20 mm
Material of screw	StSt
Distance of screws	40 mm
Material thickness	2.5 mm
Lightning current carrying capability (10/350 $\mu$ s)	200 kA
Standard	based on EN 62561-1
Weight	126 g
Customs tariff number (Comb. Nomenclature EU)	85389099
GTIN	4013364158221
PU	1 pc(s)

We reserve the right to introduce changes in performance, configuration and technology, dimensions, weights and materials in the course of technical progress. The figures are shown without obligation.